

VT1 Extensometer



Product description

The VT1 is an extensometer designed for silo inventory monitoring or other similar applications within the process weighing industry.

It's a fully welded, stainless steel, bolt-on device with a very low activation force, making it ideal for measuring force in particularly rigid structures. Its electro-polished finish is particularly appropriate for the clinical requirements of food processing environments.

It provides a high gain, analogue output signal proportional to the elastic deformation of the structural part upon which it is mounted. No structural adhesive is required during installation.

Silo inventory monitoring and other monitoring requirements in the process-weighing industry.

Applications

Silo inventory monitoring and other monitoring requirements in the process-weighing industry.

Accessories

A comprehensive range of electronic modules and accessories available

An installation kit is available to ease mounting and connection to electronics

Key features

Stainless steel construction

Environmental protection IP68 with complete hermetic sealing

High resolution

Low activation force

Easy bolt installation, no adhesives required

Shielded cable

Options

Range of cable lengths

Flying leads or cable connectors



RoHS compliant



Specifications

Rated Output (RO)	mV/V	1,7 (a 500 µm/m) nominal
Thermal effect on zero signal	%RO/ °C	0.025
Operating temperature range	°C	-30.....+70
Compensated temperature range	°C	-10.....+40
Input Resistance (RLC)	Ω	385 ±15
Output Resistance (Rout)	Ω	350 ±50
Cable length	m	5
Load cell material	-	Stainless steel
Sealing	-	Hermetic weld
Sensor body finish	-	Electro-polished
Cable gland	-	Nickel plated, PG7 type
Protection according to EN 60 529	-	IP68

Wiring

The sensor is provided with a shielded 24AWG 4-conductor cable

Please note that the cable shield isn't used to ground the load cell

Standard cable jacket: TMP

Standard cable length: 5m

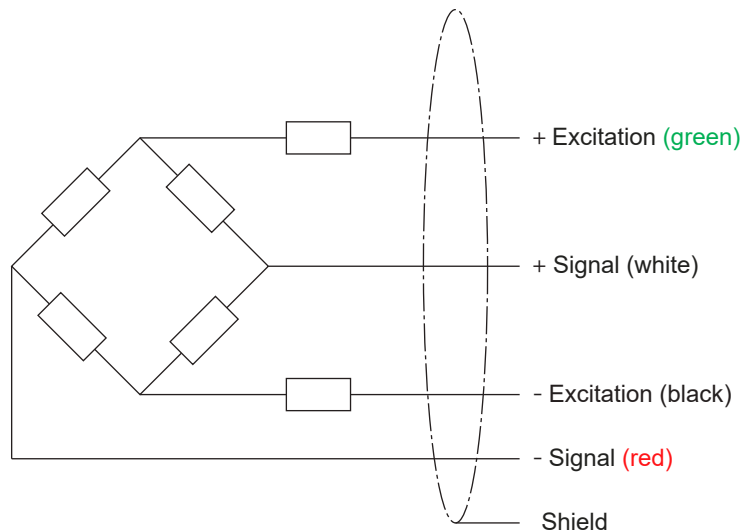

Installation kit

An installation kit can be purchased in addition to the VT1. It allows for easier mounting and connection of the sensor to client electronics. The kit contains the following items:

KA-1 Junction box, Aluminium (x1)

Socket cap screw M4x16 (Junc. box mounting) (x4)

Hex head screw-A4-80 M10x50 Full thread (x2)

Nut - A4-80 M10 (x2)

Washer - A4 10,5x21x2 (x4)

Cable ties (small) (x3)

Cable tie mounts 12,7x12,7x3,0 (x3)

Product dimensions (mm)

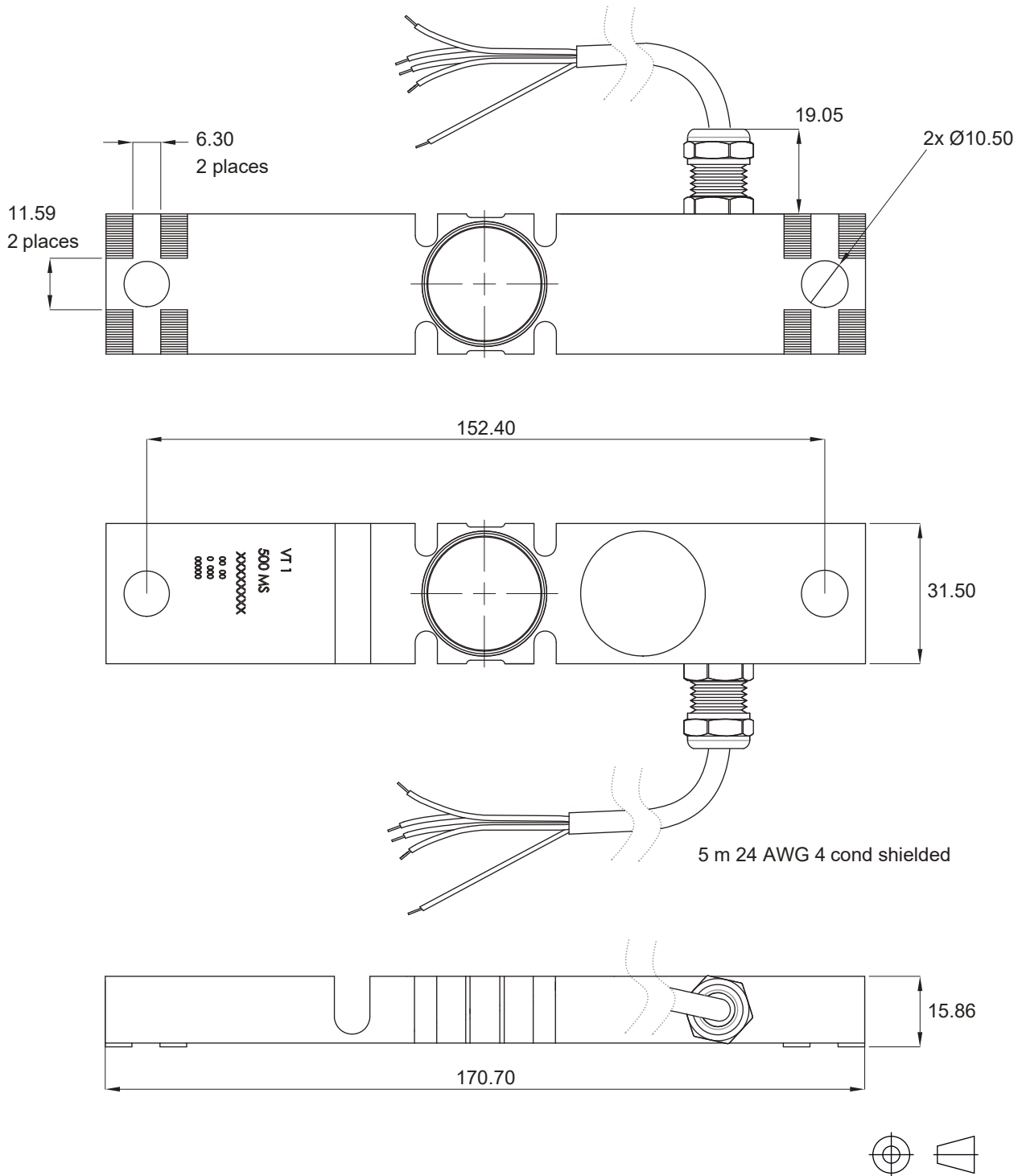

Installation

The VT1 is installed on one of the silo support legs.

It measures the elastic deformation of the leg, which varies in proportion to the weight of the silo's contents.

A full silo will exert a compressive force on the legs, shortening them.

As the silo empties and the weight reduces, the legs will elongate.

The VT1 will detect these changes, allowing for accurate inventory monitoring.

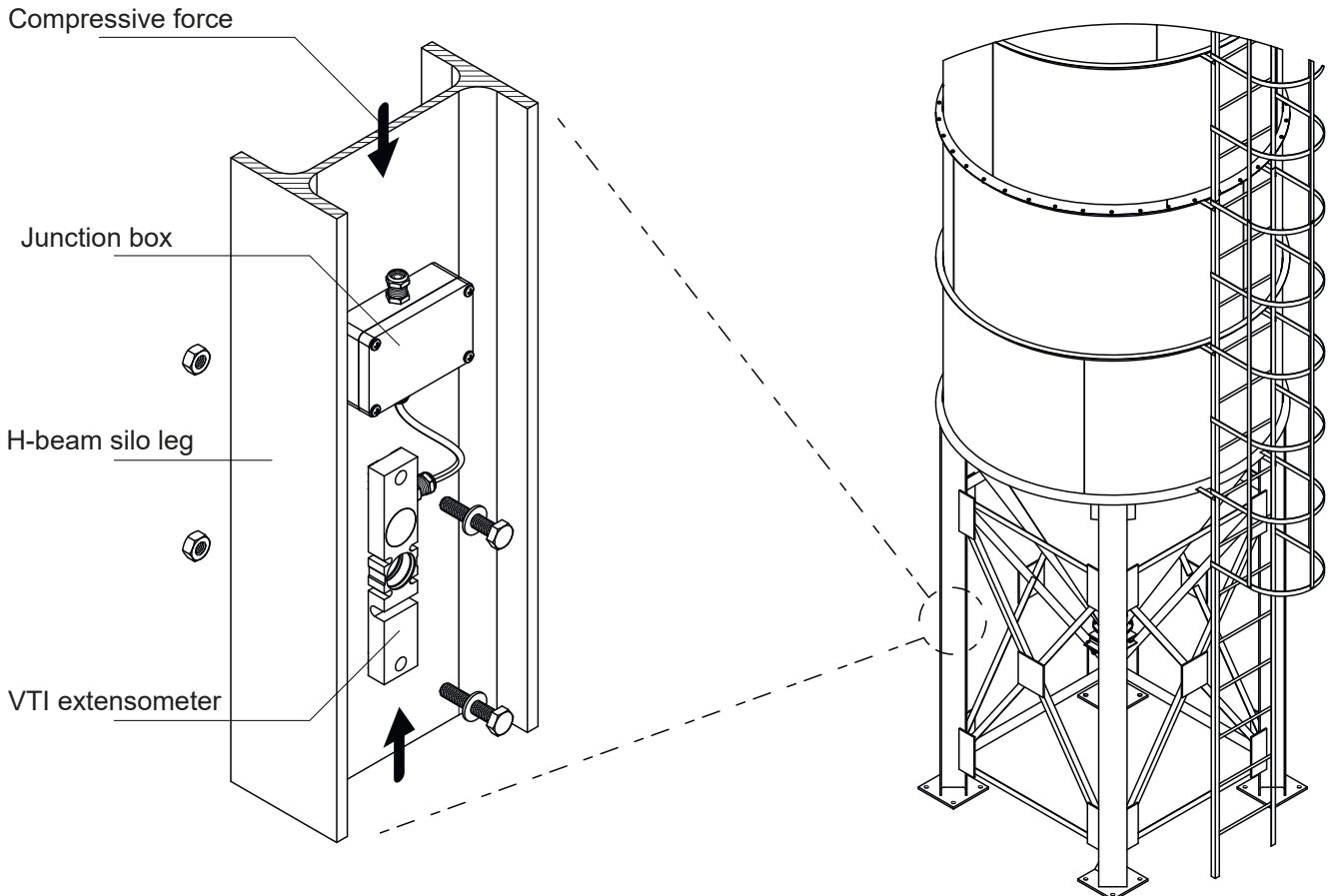

Notes

Mount the sensor and junction box directly onto one of the silo legs using the optional installation kit.

Ensure the surface is smooth, free from bumps, burrs and welds.

Position the sensor along the neutral axis, at the centre of the longest free stretch of leg. This will ensure the best performance.

Place the junction box above the sensor, with its gland pointing downwards.

The schematic above depicts a silo with H-beam legs. The VT1 can also be mounted on round or box legs.



Specifications and dimensions are subject to change without notice.